

ŠKODA iV

Charger Charger Connect Charger Connect+

Manual | Part B



ŠKODA
SIMPLY CLEVER



EN

Powered by **Eli** 

CONFIGURATION STICKER

Take the configuration sticker found in the packaging and place it on this page.

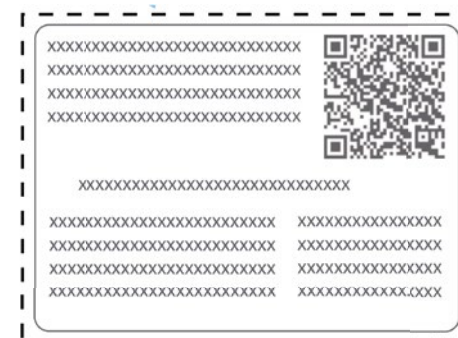
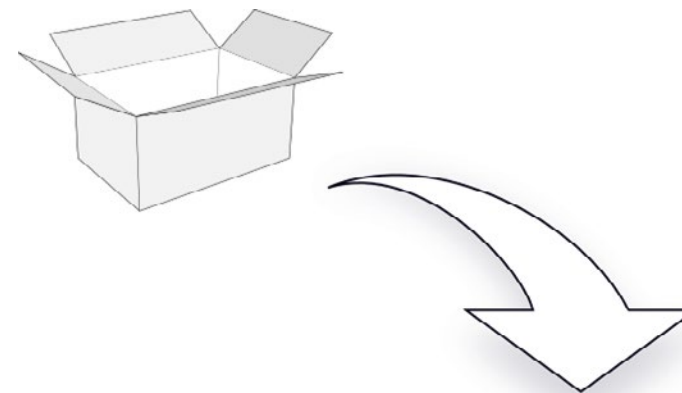

PREPARE MAIN ASSEMBLY FOR INSTALLATION

Manual part A | 5.2

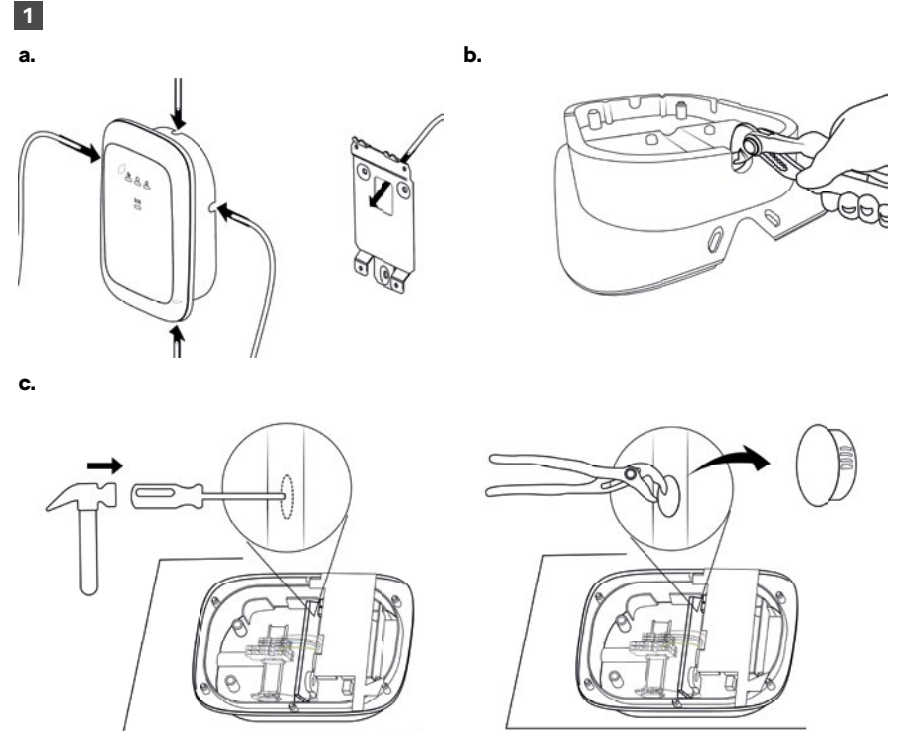

INSTALL WALL BRACKET

Manual part A | 5.1

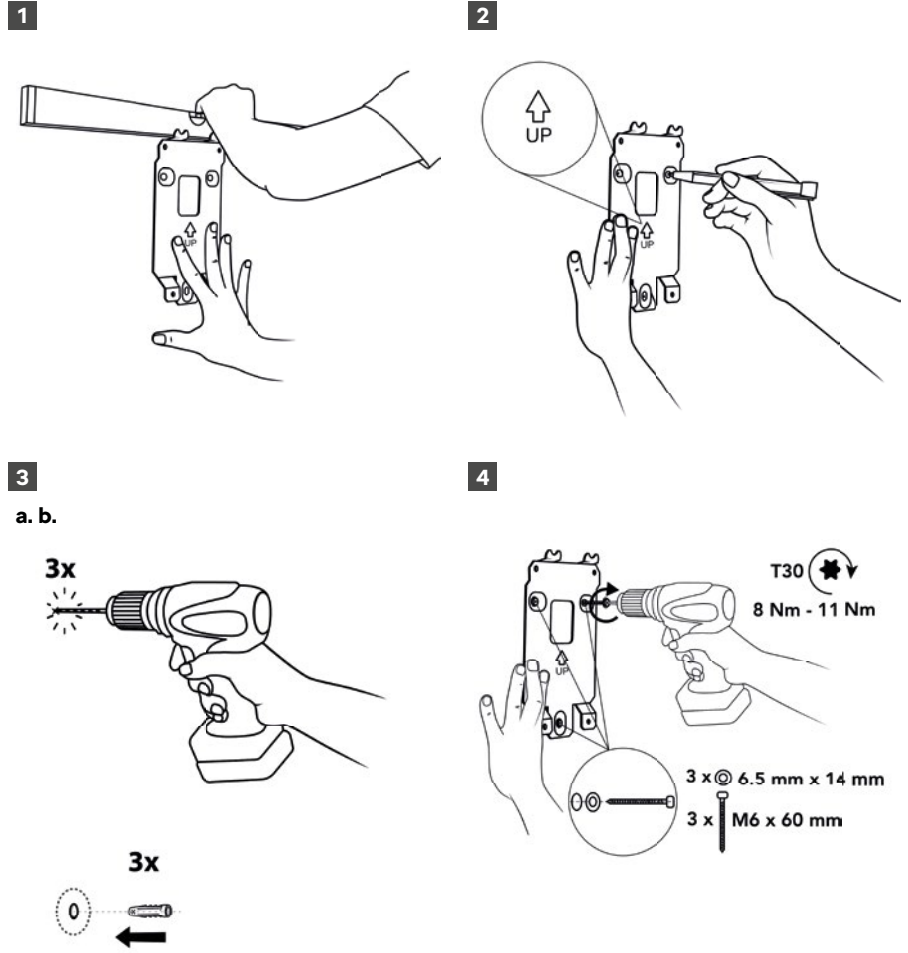

2

a.

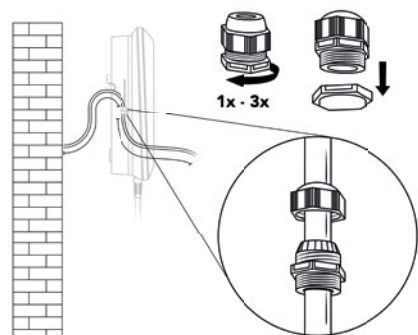

b.

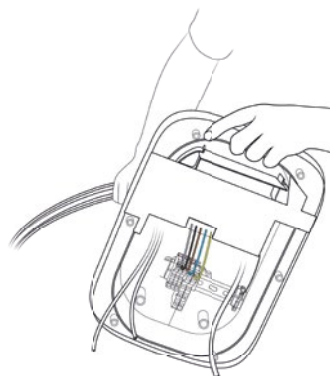

c.

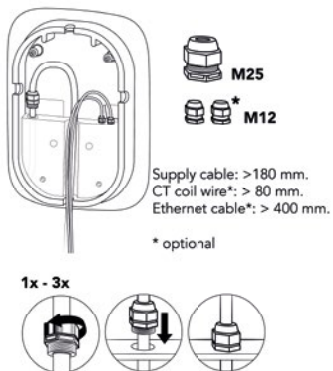

d.

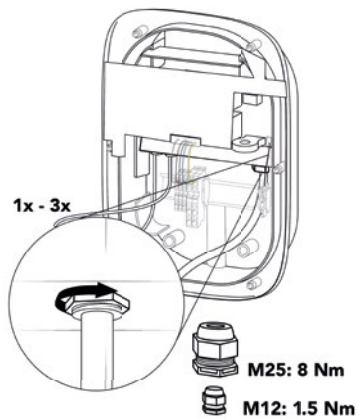

MOUNT MAIN ASSEMBLY ONTO WALL BRACKET

Manual part A | 5.3

1

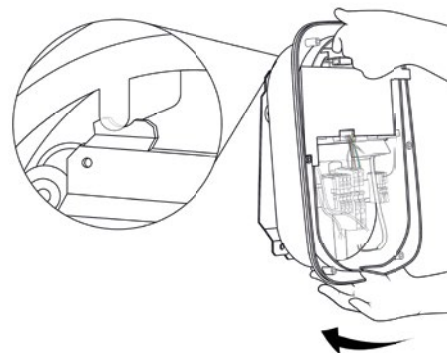

2

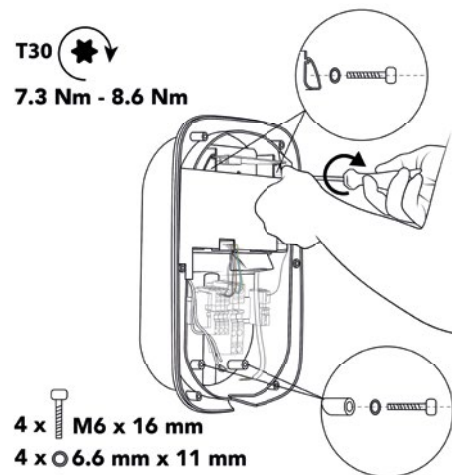

ASSEMBLE THE WALLBOX

Manual part A | 5.4

1

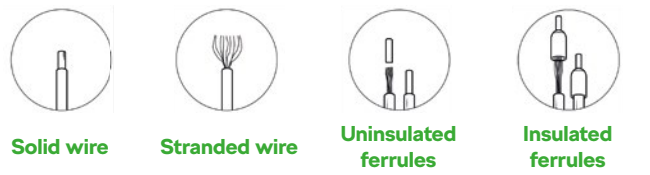

	Solid wire	Stranded wire	Uninsulated ferrules	Insulated ferrules
1-phase mains	✓	✗	✗	✓
3-phase mains	✓	✗	✓	✗
CT coil	✓	✗	✓	✓

A. ŠKODA iVCharger Connect+ with kWh meter

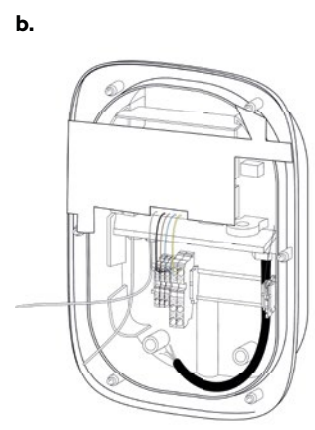
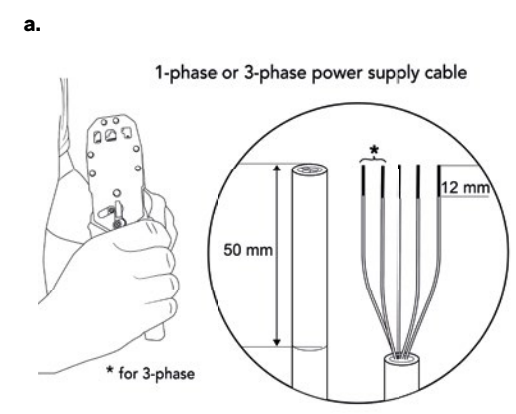
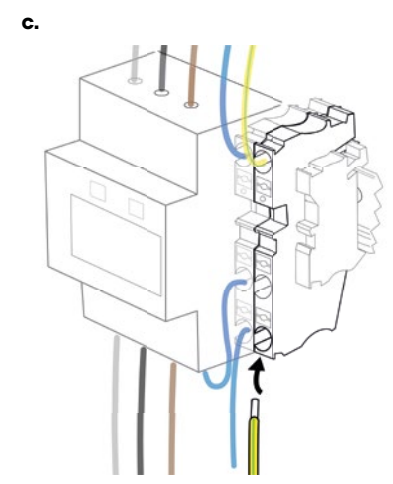
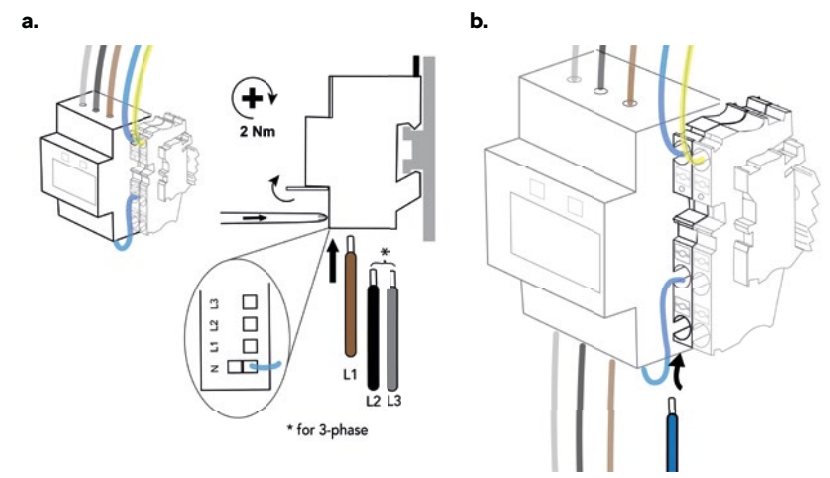

B. ŠKODA iV Charger and ŠKODA iV Charger Connect without kWh meter

a.

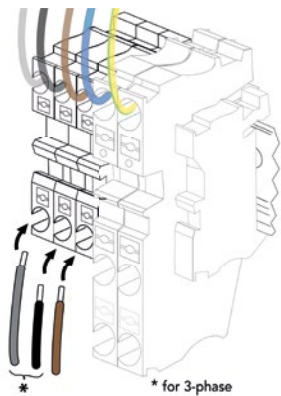

b.

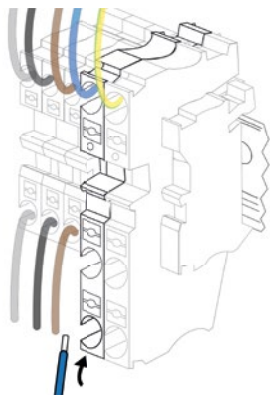

c.

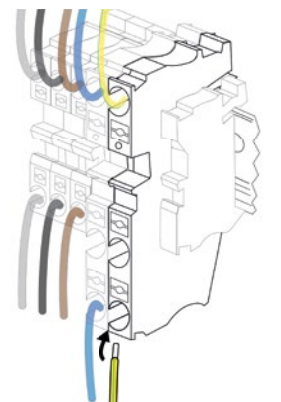

2

a.

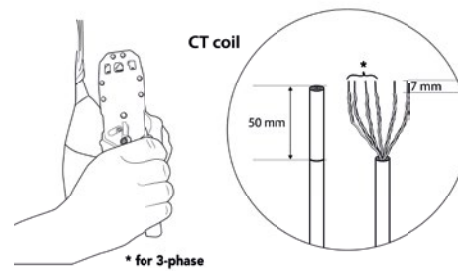

b.

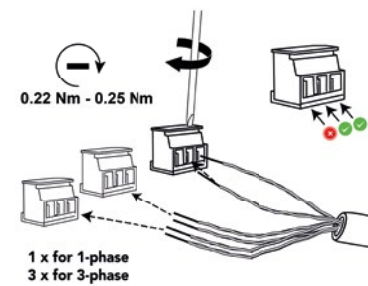

c.

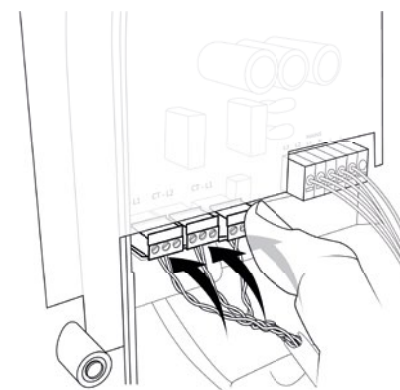

4

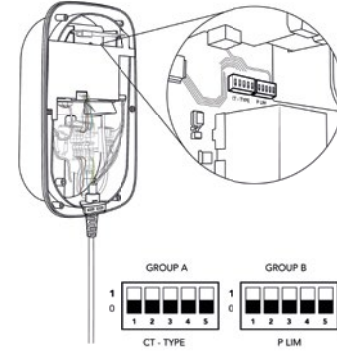

5

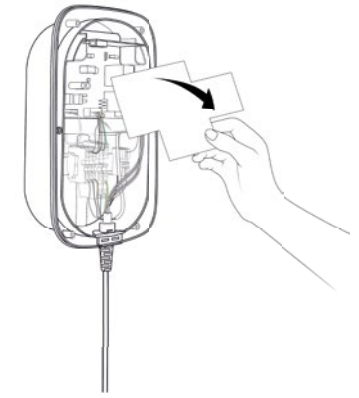

6

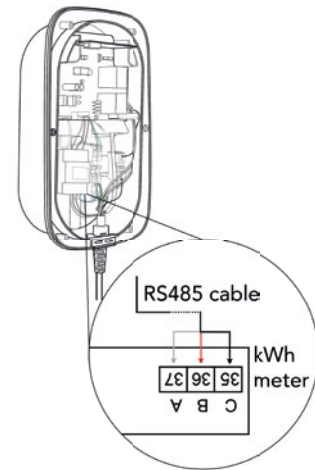

b.

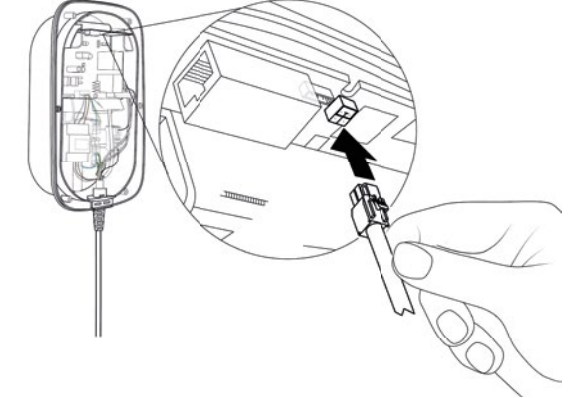

3

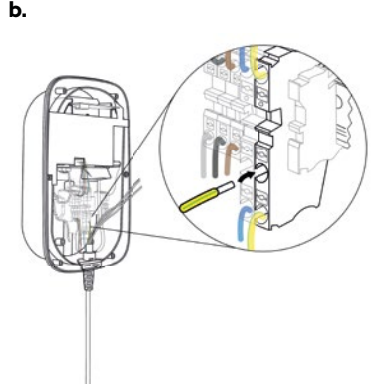
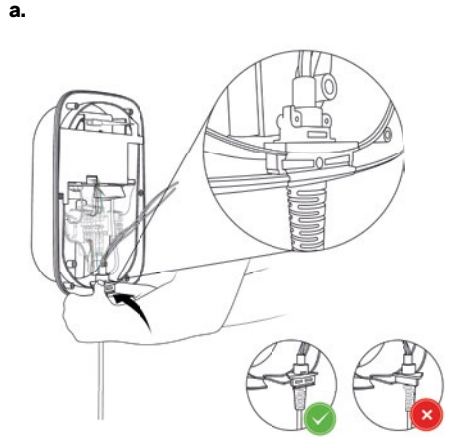

c.

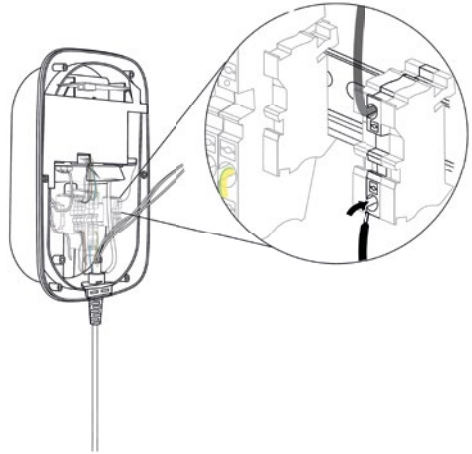

d.

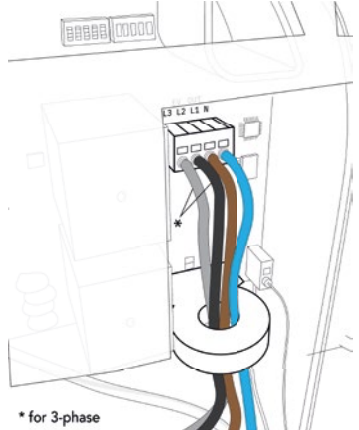

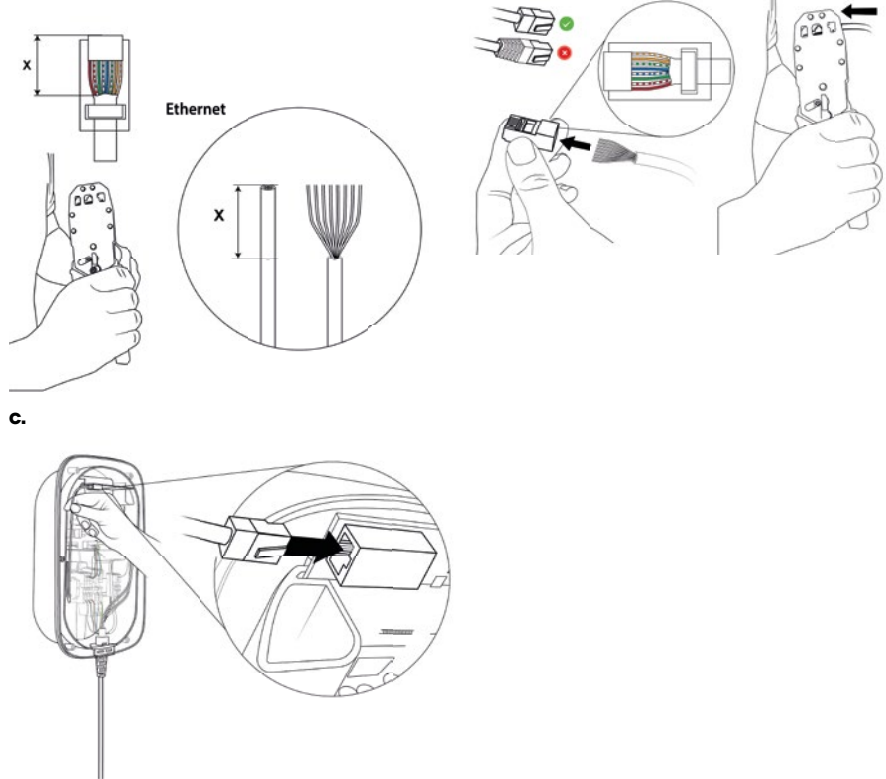
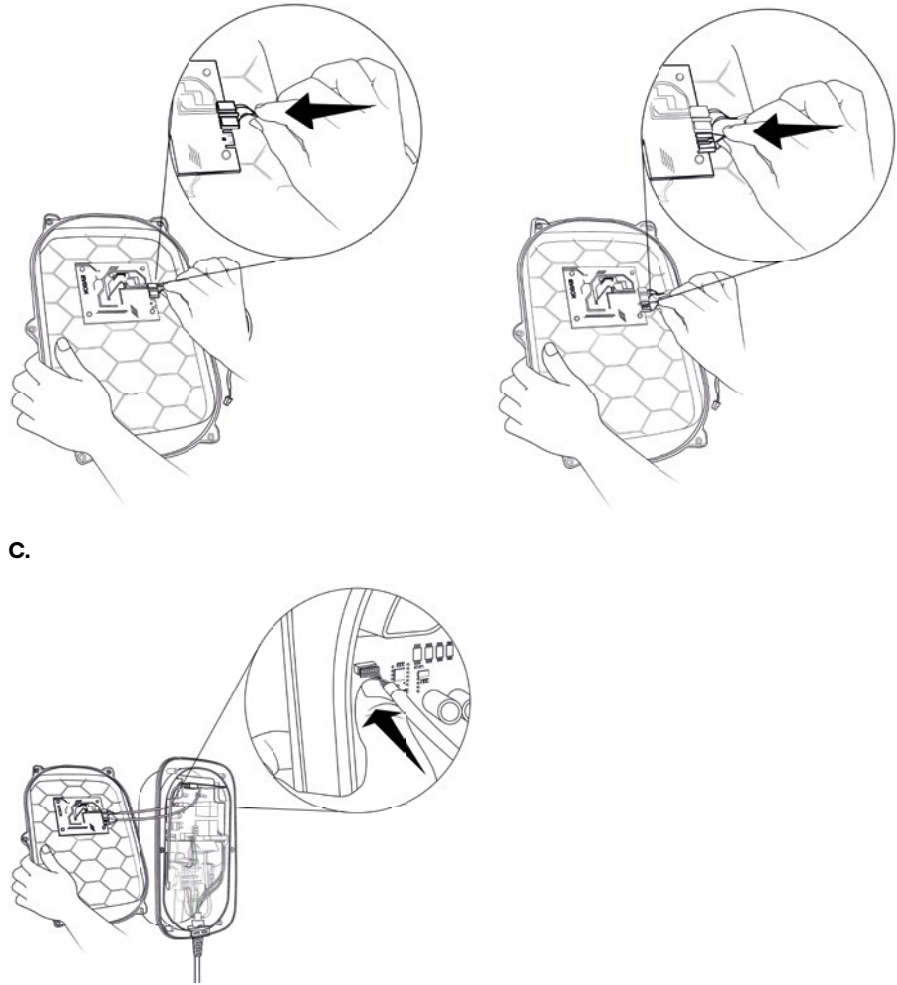

9

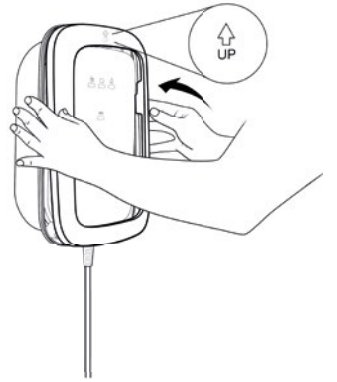

f.

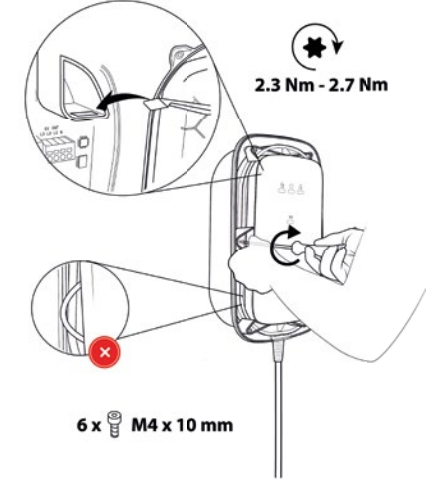

11

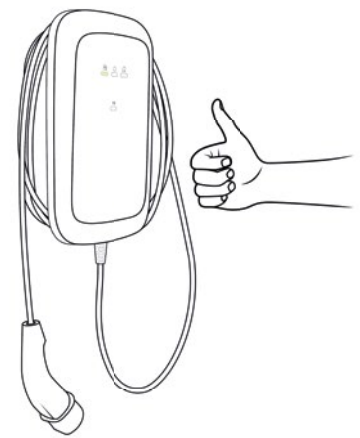

10

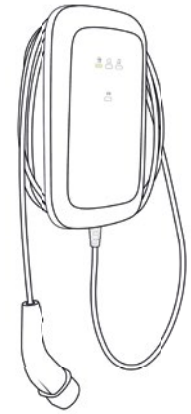

d.

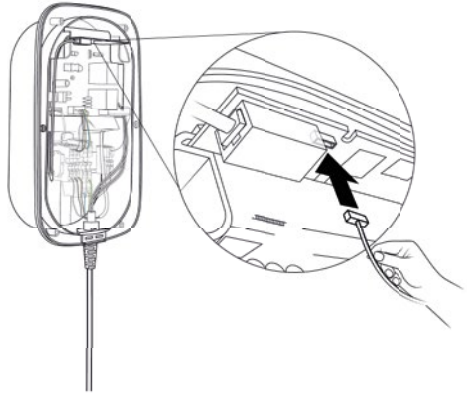

e.

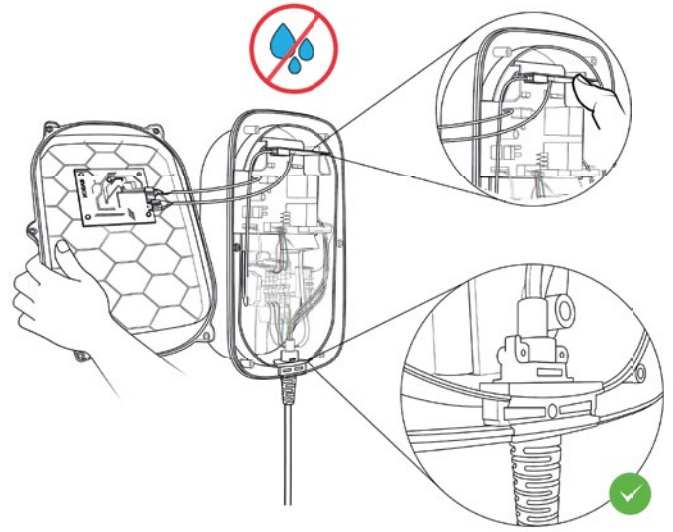

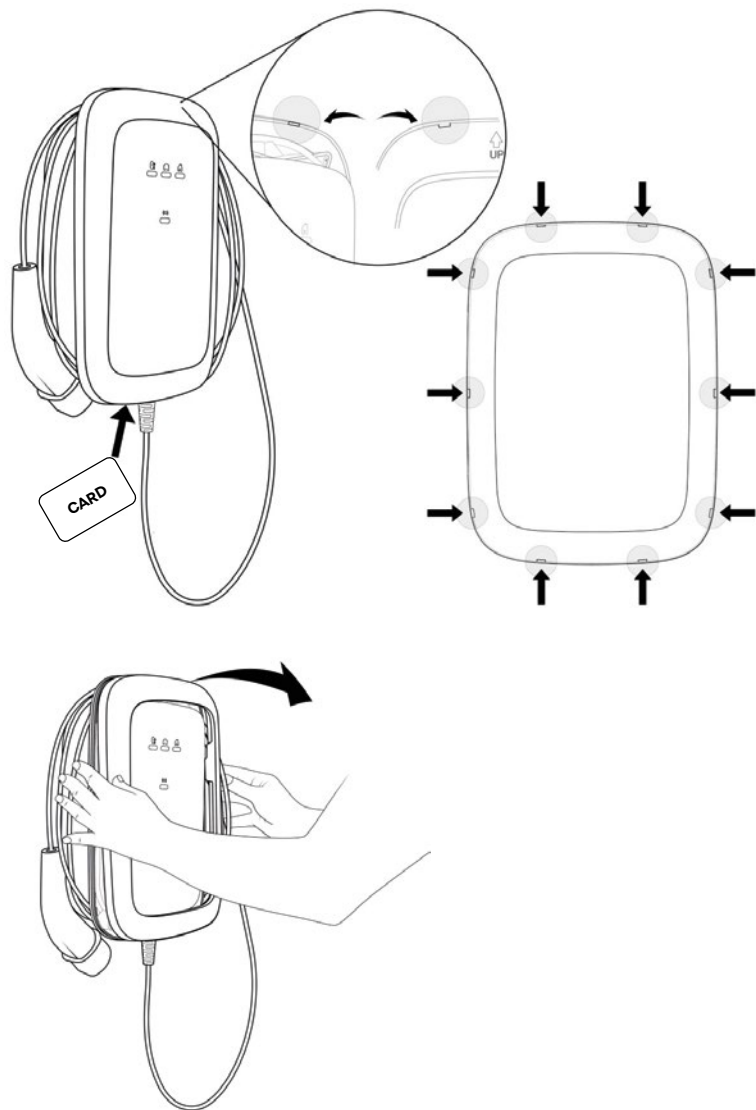

- EN** - The information on the technical data, design, equipment, materials, guarantees and outside appearance refer to the period when the mounting instructions are sent to print. The manufacturer reserves the right to changes (including the change in technical parameters with reference to the individual model measures).
- CZ** - Informace o technických údajích, konstrukci, vybavení, materiálech, zárukách a vnějším vzhledu se vztahují na období zadávání montážního návodu do tisku. Výrobce si vyhrazuje právo změny (včetně změny technických parametrů se změnami jednotlivých modelových opatření).
- DE** - Informationen über technische Angaben, Konstruktion, Ausrüstung, Werkstoffe, Garantien und äußerliches Aussehen beziehen sich auf den Zeitraum, in dem die Montageanleitung in Druck gegeben wurde. Der Hersteller behält sich das Änderungsrecht vor (samt Änderungen der technischen Parameter mit Änderungen einzelner Modellmaßnahmen).
- ES** - Las informaciones sobre los datos técnicos, la construcción, el equipo, los materiales, la garantía y el aspecto son válidas para el período en que la instrucción de montaje es mandada a imprimir. El fabricante se reserva el derecho de cambiar (incluyendo el cambio de los parámetros técnicos con los cambios de las distintas medidas modelo).
- FR** - Les informations sur les données techniques, de construction, d'équipement, de matériaux, de garanties et sur l'aspect concernent la période de mise sous presse des instructions de montage. Le fabricant se réserve le droit de modification (incluant les modifications des paramètres techniques avec des modifications particulières des mesures de modelage).
- IT** - Informazioni dei dati tecnici, costruzione, corredo, materiali, garanzie e l'aspetto esterno riguardano il periodo, quando l'istruzione per il montaggio sono stati dati alle stampe. Il produttore si riserva il diritto di eseguire le modifiche (compreso la modifica dei parametri tecnici riguardanti la modifiche dei modelli).
- SV** - Upplysningarna om tekniska data, konstruktion, utrustning, materialier, garantier, och om yttre utseendet, gäller tidrymden då montageanledningen givits i uppdrag för tryckning. Producenten förbehåller sig rätten till förändringar (inkl. modifikation av tekniska parametrar sammen med ändringar av enskilda vmodellåtgärder).
- NL** - Informaties over de technische gegevens, constructie, uitrusting, materialen, garanties en het uiterlijk hebben betrekking op de periode wanneer de montageaanwijzing in druk wordt gegeven. De fabrikant behoudt zich het recht van de wijziging voor (inclusief wijziging van de technische parameters met de wijzigingen van de afzonderlijke modelvoorzieningen).
- PL** - Informacje o danych technicznych, konstrukcji, wyposażeniu, materiałach, gwarancjach i wyglądzie zewnętrznym odnoszą się do okresu zlecenia instrukcji montażowej do druku. Producent zastrzega sobie prawo zmiany (włącznie ze zmianą parametrów technicznych ze zmianami poszczególnych modelowych posunięć).
- SK** - Informácie o technických údajoch, konštrukcii, vybavení, materiáloch, zárukách a vonkajšom vzhľade sa vzťahujú na obdobie zadávania montážneho návodu do tlače. Výrobca si vyhradzuje právo zmeny (vrátane zmeny technických parametrov so zmenami jednotlivých modelových opatrení).
- RU** - Информация о технических данных, конструкции, оснащении, материалах, гарантии и внешнего вида соответствует периоду передачи заказа инструкции по монтажу в печать. Производитель оставляет за собой право внесения изменений (в том числе изменений технических параметров с изменениями отдельных модельных мер).
- HU** - A műszaki adatokra, a konstrukcióra, a felhasznált anyagokra, a garanciára és a termék kivetelére vonatkozó adatok a jelen anyag nyomdába kerülésének idején érvényben lévő állapotot tükrözik. A gyártó fenntartja magának a változtatások jogát (azokat a műszaki változtatásokat is beleértve, amelyek a modellmódosítások miatt következnek be).
- RO** - Informațiile privind datele tehnice, construcția, dotarea, materialele, garanțiile și aspectul exterior se referă la momentul prezentării instrucțiunilor de montaj pentru tipărire. Fabrică își rezervă dreptul de a face schimbări (inclusiv schimbarea parametrilor tehnici cu schimbările măsurilor pentru diferitele modele).



ŠKODA
SIMPLY CLEVER

Distribution of ŠKODA iV Charger,
ŠKODA iV Charger Connect
and ŠKODA iV Charger Connect+ by

Elli  **A Brand of the Volkswagen Group**

Volkswagen Group Charging GmbH
Mollstraße 1
10178 Berlin

Germany

skoda-support@elli.eco
www.elli.eco

ARTICLE NO of MANUAL
2023209